



HIGH SPEED MACRO PUNCHING SOLUTIONS

By macroperforation we are able to give to thermoplastic films the optimal properties for the packaging of products for both food and industrial use.

MOD. SM-SV - SM-SV2

Punching unit MOD. SM-SV - SM-SV2 are a slim solution usually suitable for installing on bag making machine, in case of tight space. The double bridge allows both twice the speed or holes narrower to each other.

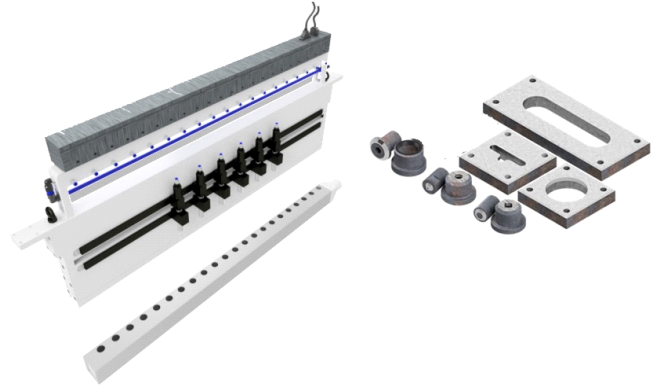

Features

Max material width	2000mm
Max speed	250 meters per minute for elastic material and 120 for rigid material
Max Frequency	4800 holes per minute with a double-sided bridge
Diameter of the holes]	from 2mm up to 50mm
Shaped holes]	yes (handle, oval, earhole, etc.)
Not completed cut holes	Yes
Installation on	bag making machine, extruder, slitler, printing machine and so on
Holes on register	Yes
Encoder to synchronize the speed	Yes
Material that could be processed	PE, PP, paper, foam non-woven, coated material and so on
Pattern	linear, Zig zag and custom
Job memory	Yes
Operator language	Yes
Easily set up punches across	Yes
User friendly software	Yes
remote assistance	Yes
Touch screen	Yes with predisposition 4.0

